

LEGEND

- PURGE AIR
- COOLING WATER
- CONTROL AIR

FCS Fossil Consulting Services, Inc.
Columbia, Maryland



SAMPLE FLOW DIAGRAM

GE COMBUSTION TURBINES

ATOMIZING AIR SYSTEM

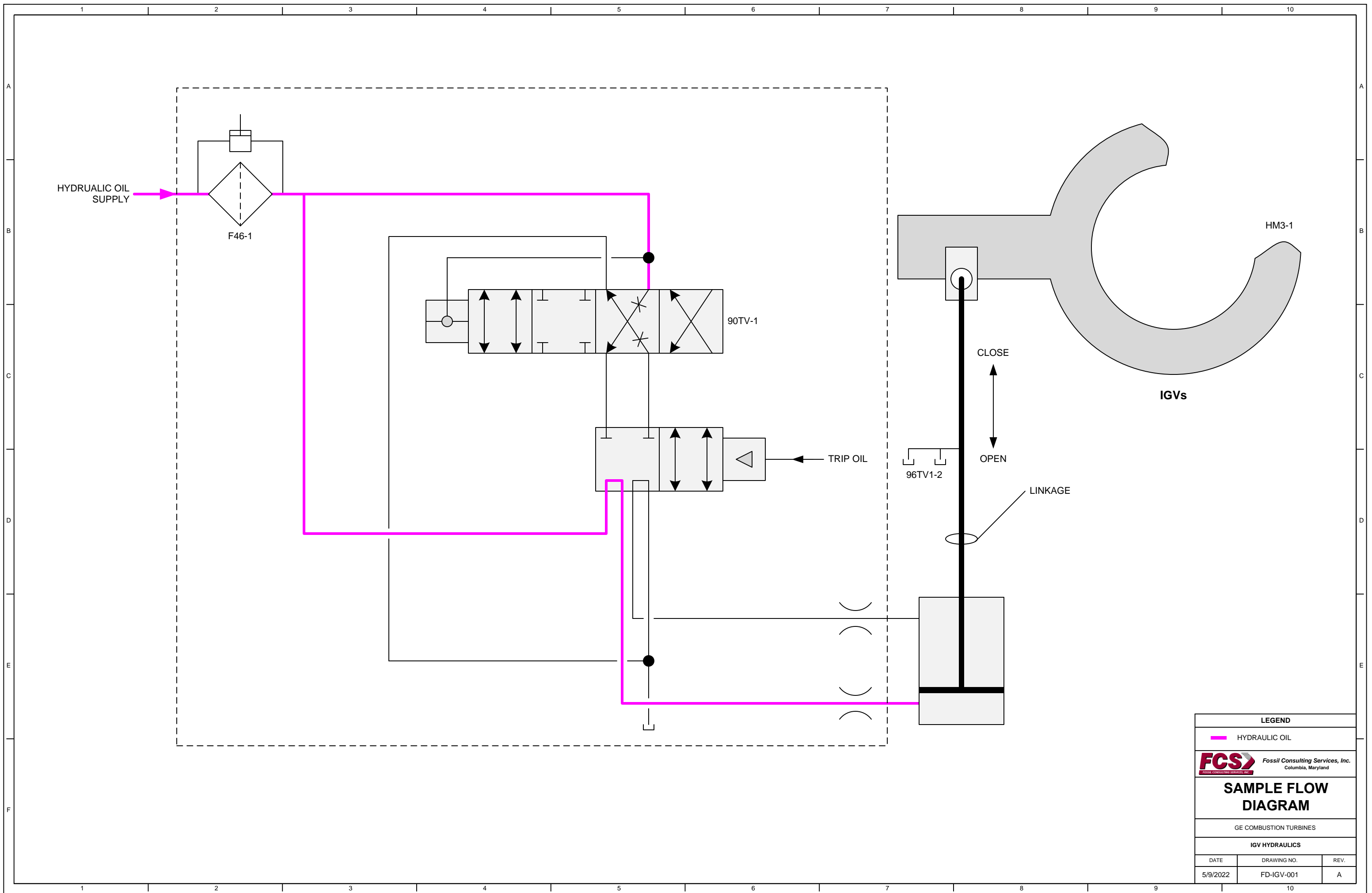
DATE	DRAWING NO.	REV.
5/10/2022	FD-AA-001	A



LEGEND		
	HYDRAULIC OIL	
 Fossil Consulting Services, Inc. <small>Columbia, Maryland</small>		
SAMPLE FLOW DIAGRAM		
GE COMBUSTION TURBINES		
IGV HYDRAULICS		
DATE	DRAWING NO.	REV.
5/9/2022	FD-IGV-001	A

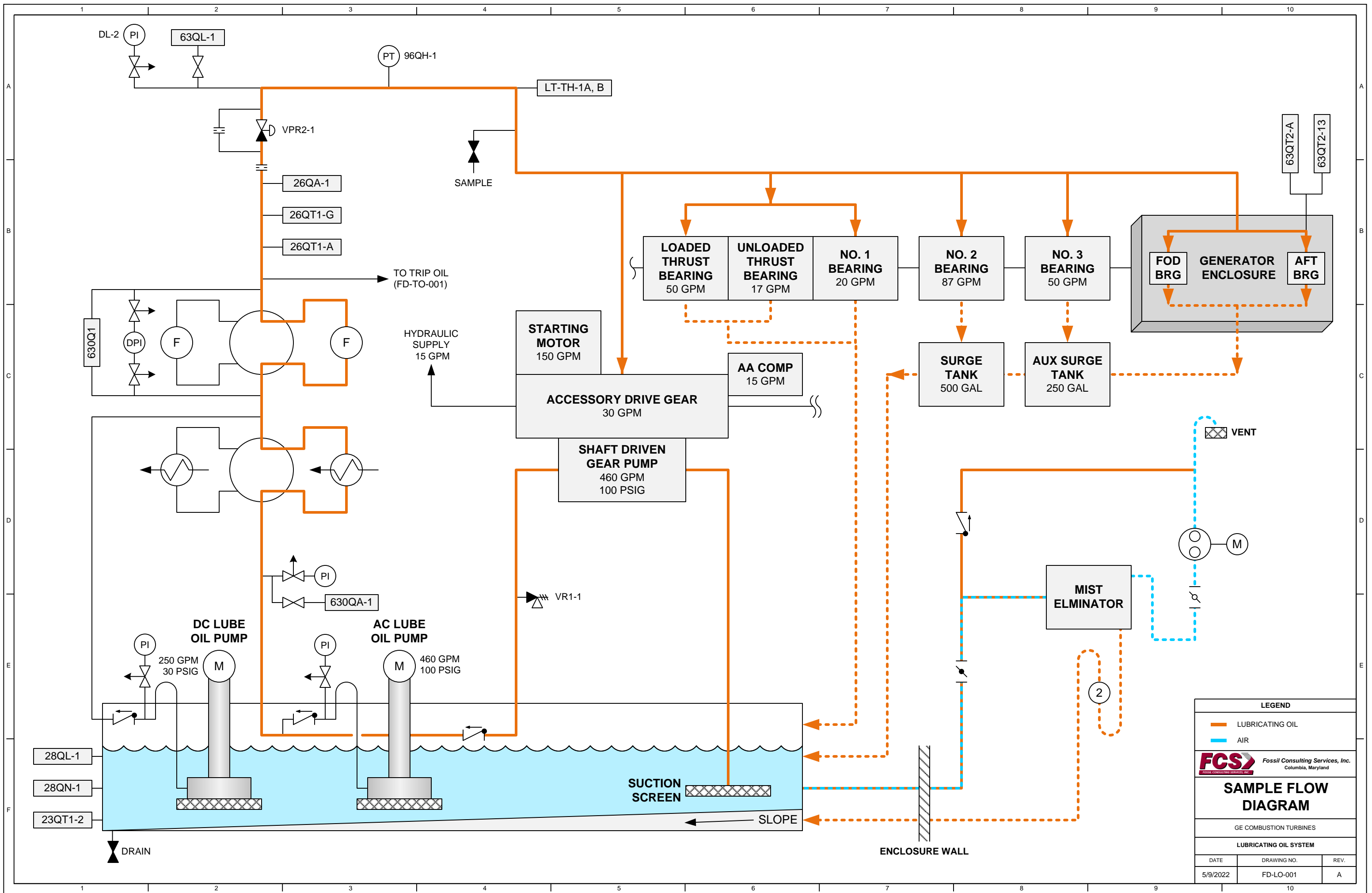

LEGEND		
	LUBRICATING OIL	
	AIR	
Fossil Consulting Services, Inc. <small>Columbia, Maryland</small>		
SAMPLE FLOW DIAGRAM		
GE COMBUSTION TURBINES		
LUBRICATING OIL SYSTEM		
DATE	DRAWING NO.	REV.
5/9/2022	FD-LO-001	A

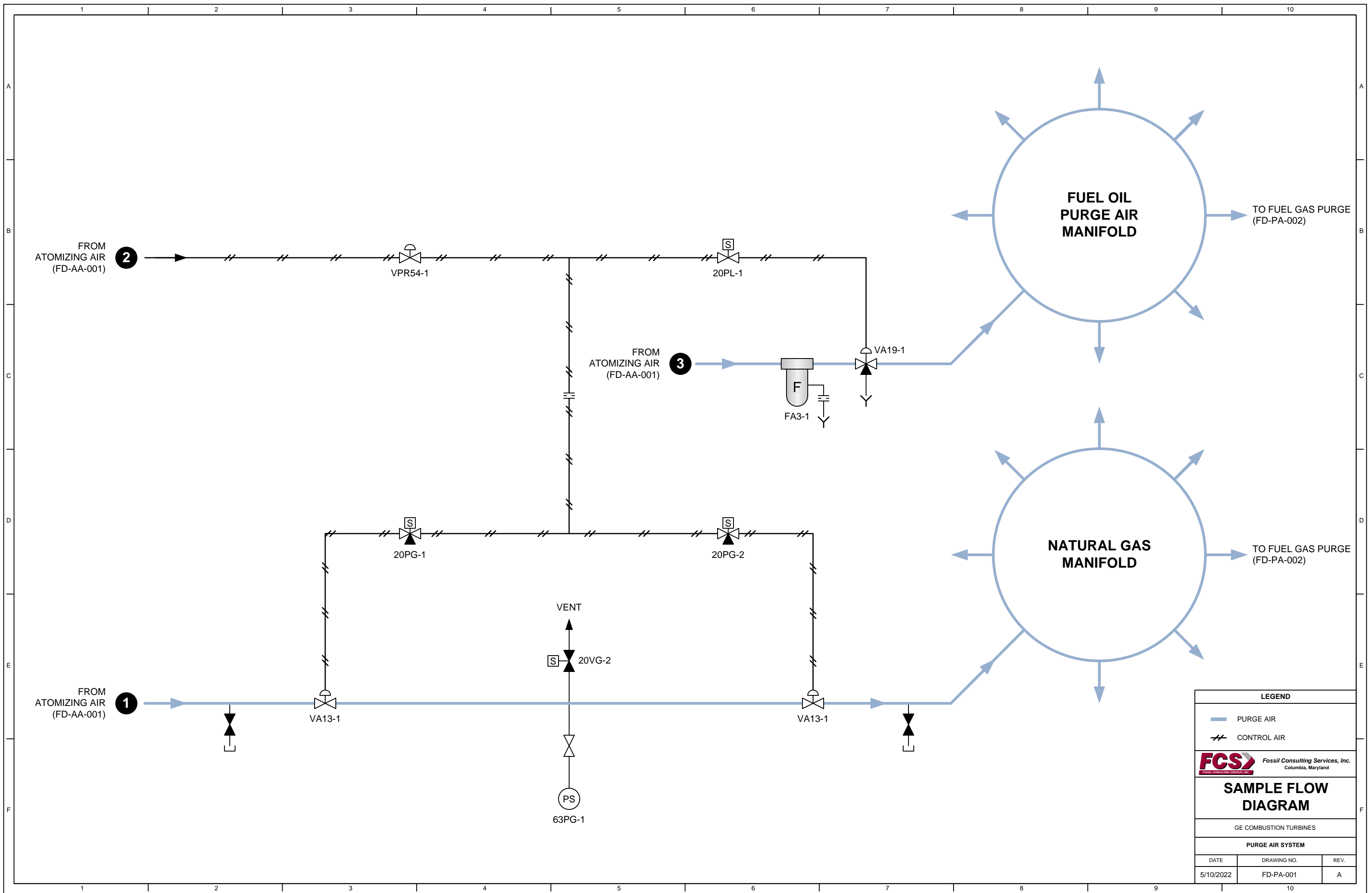

LEGEND

- PURGE AIR
- // CONTROL AIR

FCS Fossil Consulting Services, Inc.
Columbia, Maryland

SAMPLE FLOW DIAGRAM

GE COMBUSTION TURBINES

PURGE AIR SYSTEM

DATE	DRAWING NO.	REV.
5/10/2022	FD-PA-001	A

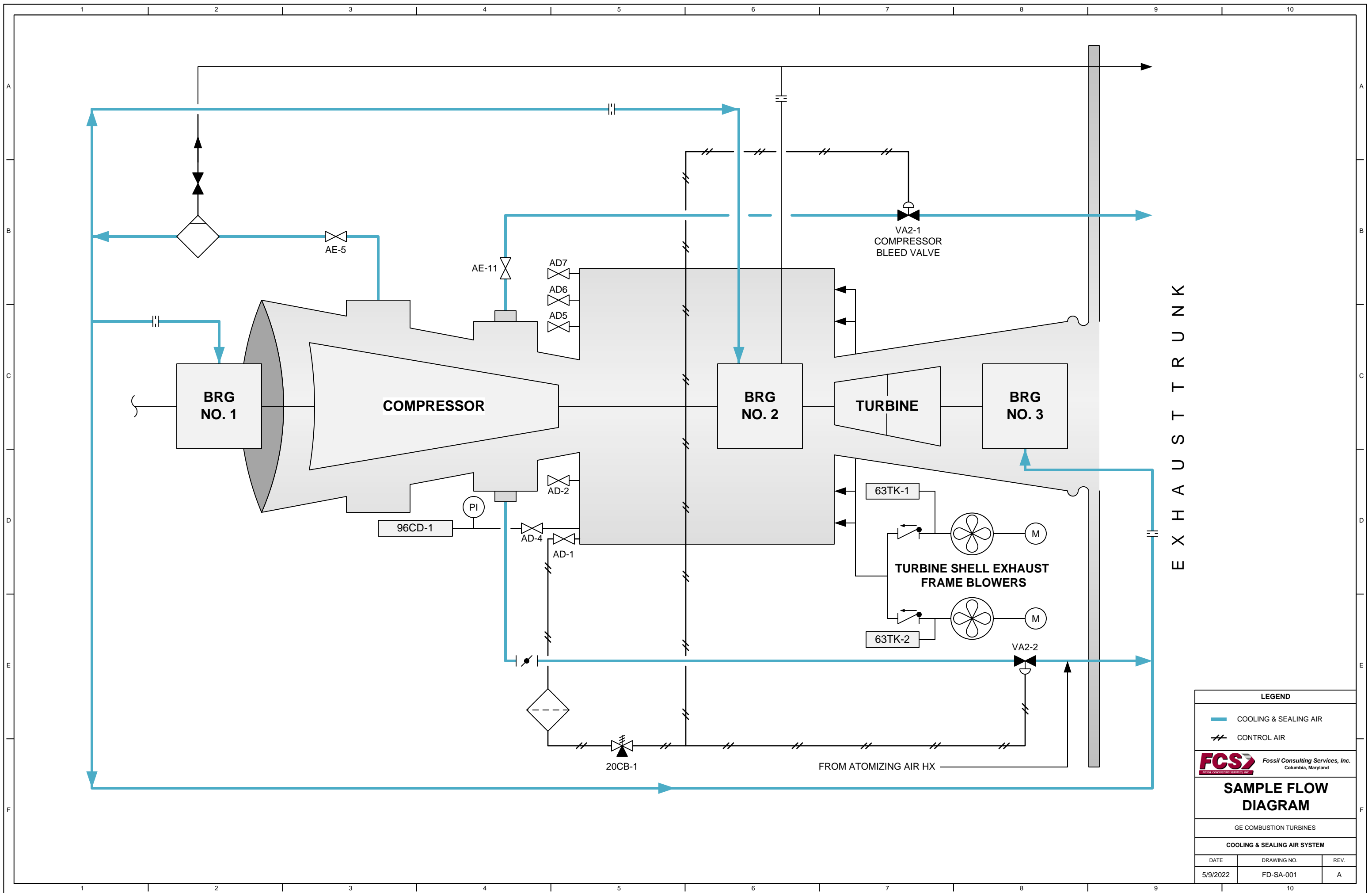

E X H A U S T T R U N K

LEGEND		
	COOLING & SEALING AIR	
	CONTROL AIR	
Fossil Consulting Services, Inc. Columbia, Maryland		
SAMPLE FLOW DIAGRAM		
GE COMBUSTION TURBINES		
COOLING & SEALING AIR SYSTEM		
DATE	DRAWING NO.	REV.
5/9/2022	FD-SA-001	A

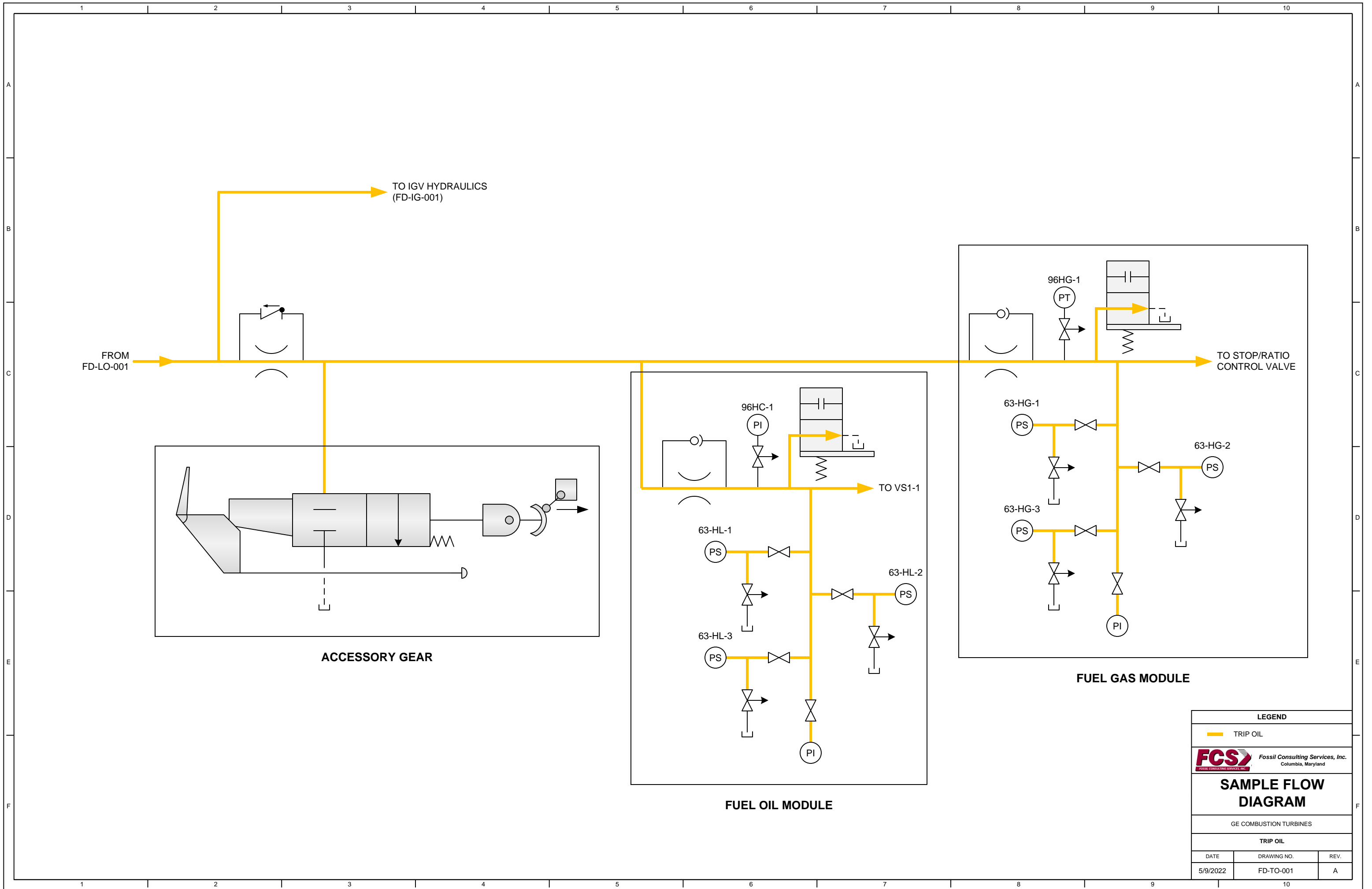

LEGEND		
TRIP OIL		
FCS Fossil Consulting Services, Inc. Columbia, Maryland		
SAMPLE FLOW DIAGRAM		
GE COMBUSTION TURBINES		
TRIP OIL		
DATE	DRAWING NO.	REV.
5/9/2022	FD-TO-001	A

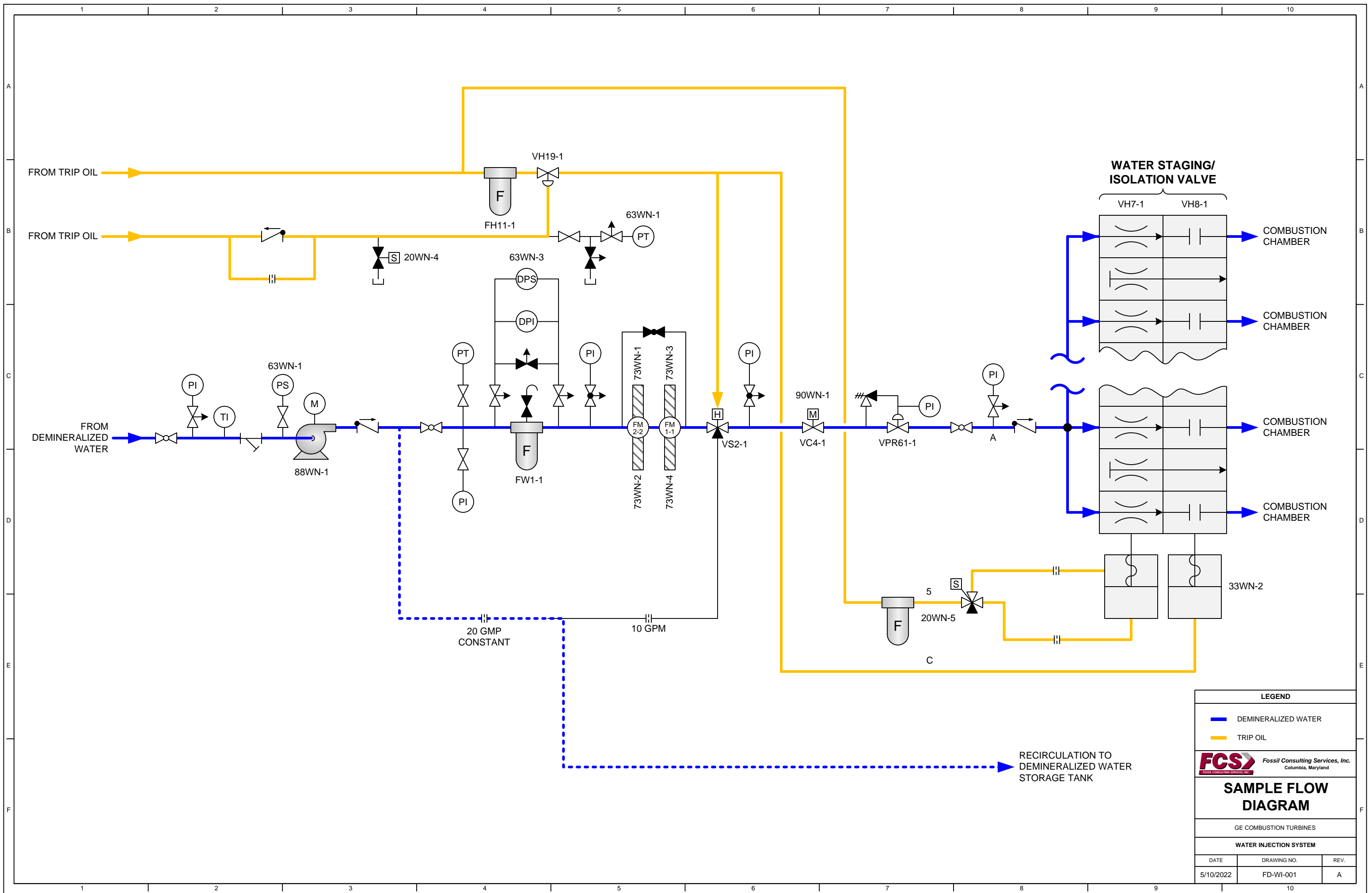

LEGEND

- DEMINERALIZED WATER
- TRIP OIL

FCS Fossil Consulting Services, Inc.
Columbia, Maryland

SAMPLE FLOW DIAGRAM

GE COMBUSTION TURBINES

WATER INJECTION SYSTEM

DATE	DRAWING NO.	REV.
5/10/2022	FD-WI-001	A

RECIRCULATION TO
DEMINERALIZED WATER
STORAGE TANK

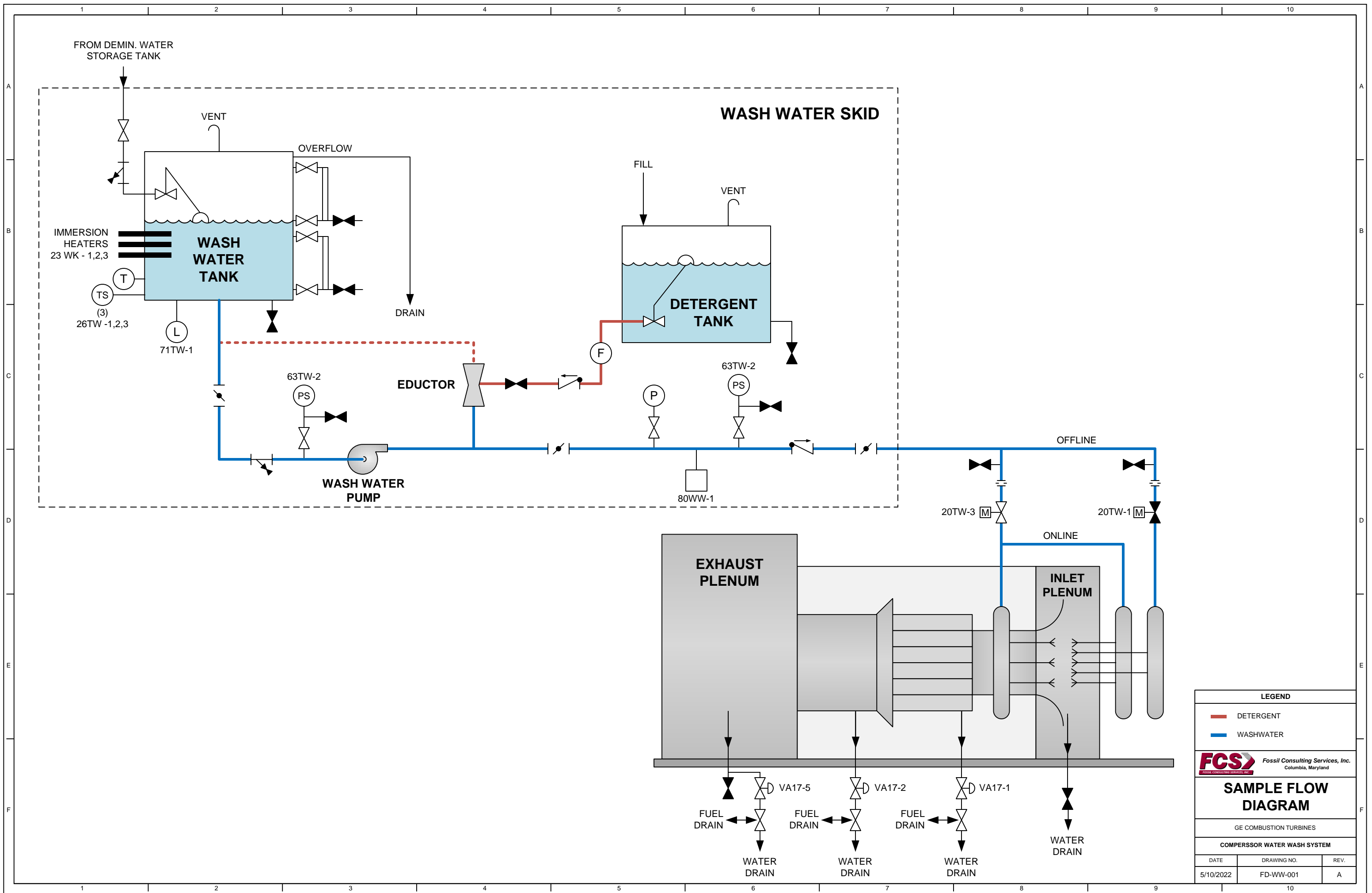

LEGEND		
—	DETERGENT	
—	WASHWATER	
FCS Fossil Consulting Services, Inc. Columbia, Maryland		
SAMPLE FLOW DIAGRAM		
GE COMBUSTION TURBINES		
COMPRESSOR WATER WASH SYSTEM		
DATE	DRAWING NO.	REV.
5/10/2022	FD-WW-001	A

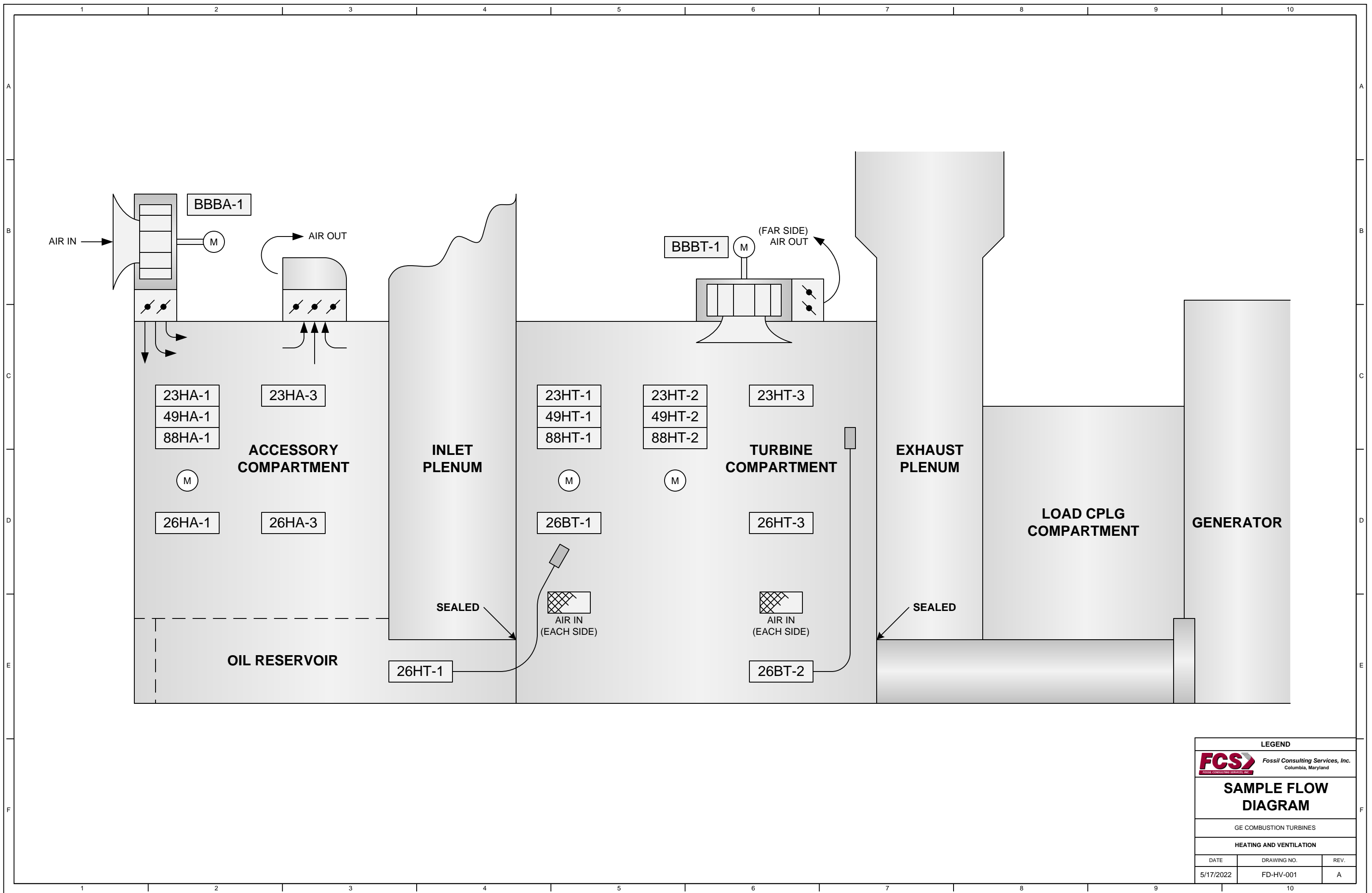

LEGEND		
 Fossil Consulting Services, Inc. Columbia, Maryland		
SAMPLE FLOW DIAGRAM		
GE COMBUSTION TURBINES		
HEATING AND VENTILATION		
DATE	DRAWING NO.	REV.
5/17/2022	FD-HV-001	A

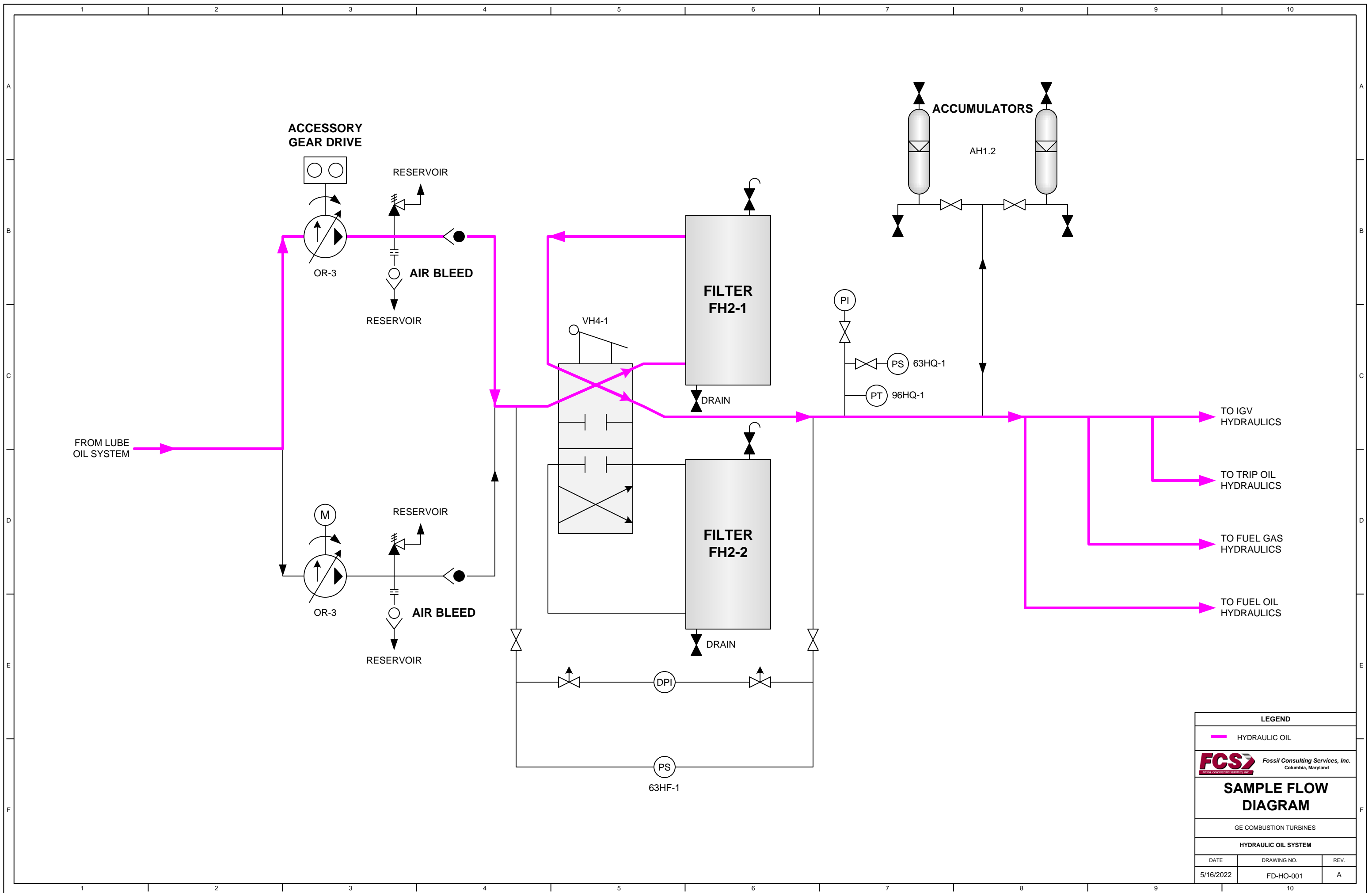

LEGEND		
HYDRAULIC OIL		
Fossil Consulting Services, Inc. Columbia, Maryland		
SAMPLE FLOW DIAGRAM		
GE COMBUSTION TURBINES		
HYDRAULIC OIL SYSTEM		
DATE	DRAWING NO.	REV.
5/16/2022	FD-HO-001	A

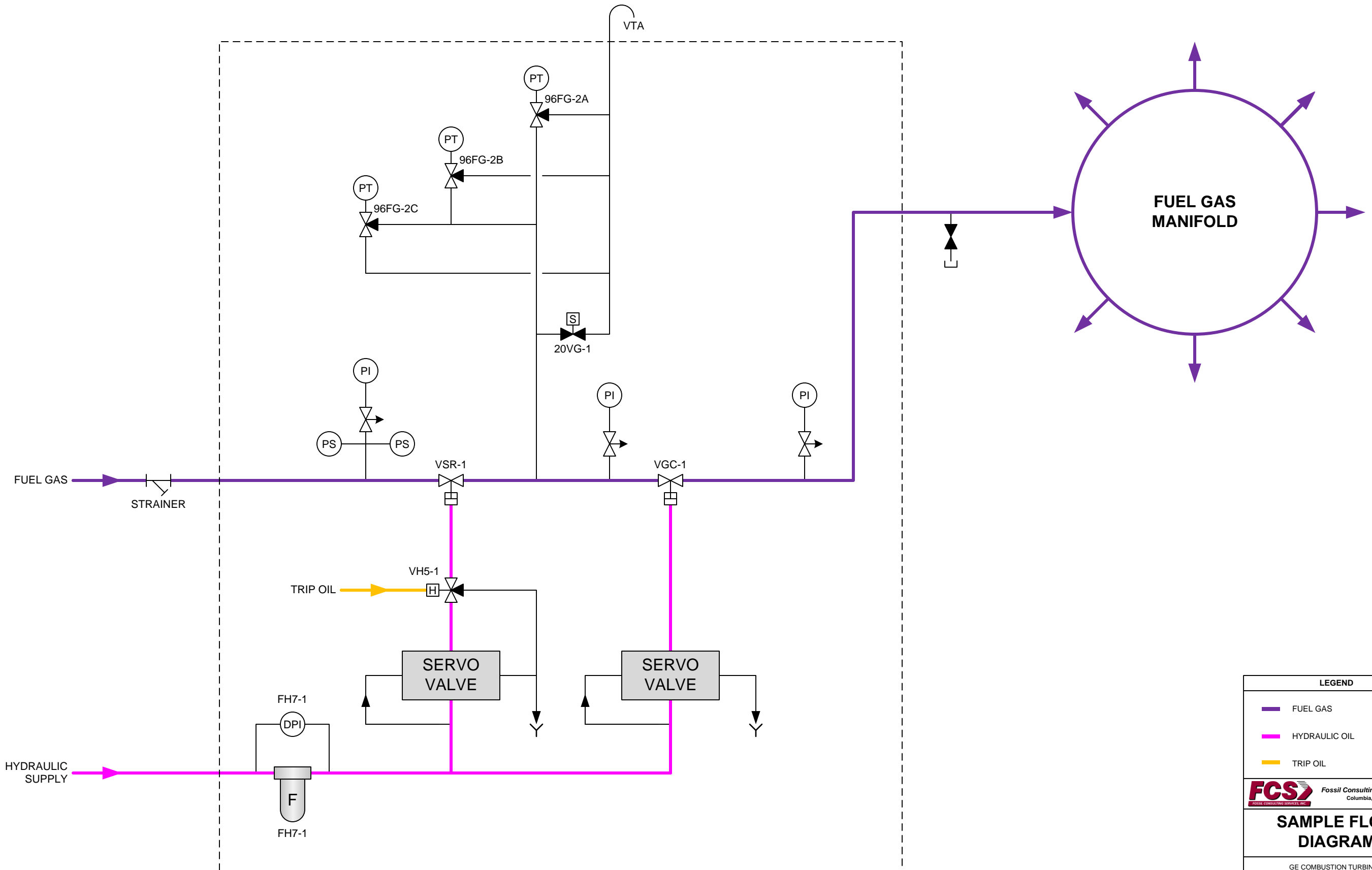

LEGEND

- FUEL GAS
- HYDRAULIC OIL
- TRIP OIL

FCS Fossil Consulting Services, Inc.
Columbia, Maryland

SAMPLE FLOW DIAGRAM

GE COMBUSTION TURBINES

FUEL GAS SYSTEM

DATE	DRAWING NO.	REV.
5/10/2022	FD-FG-001	A

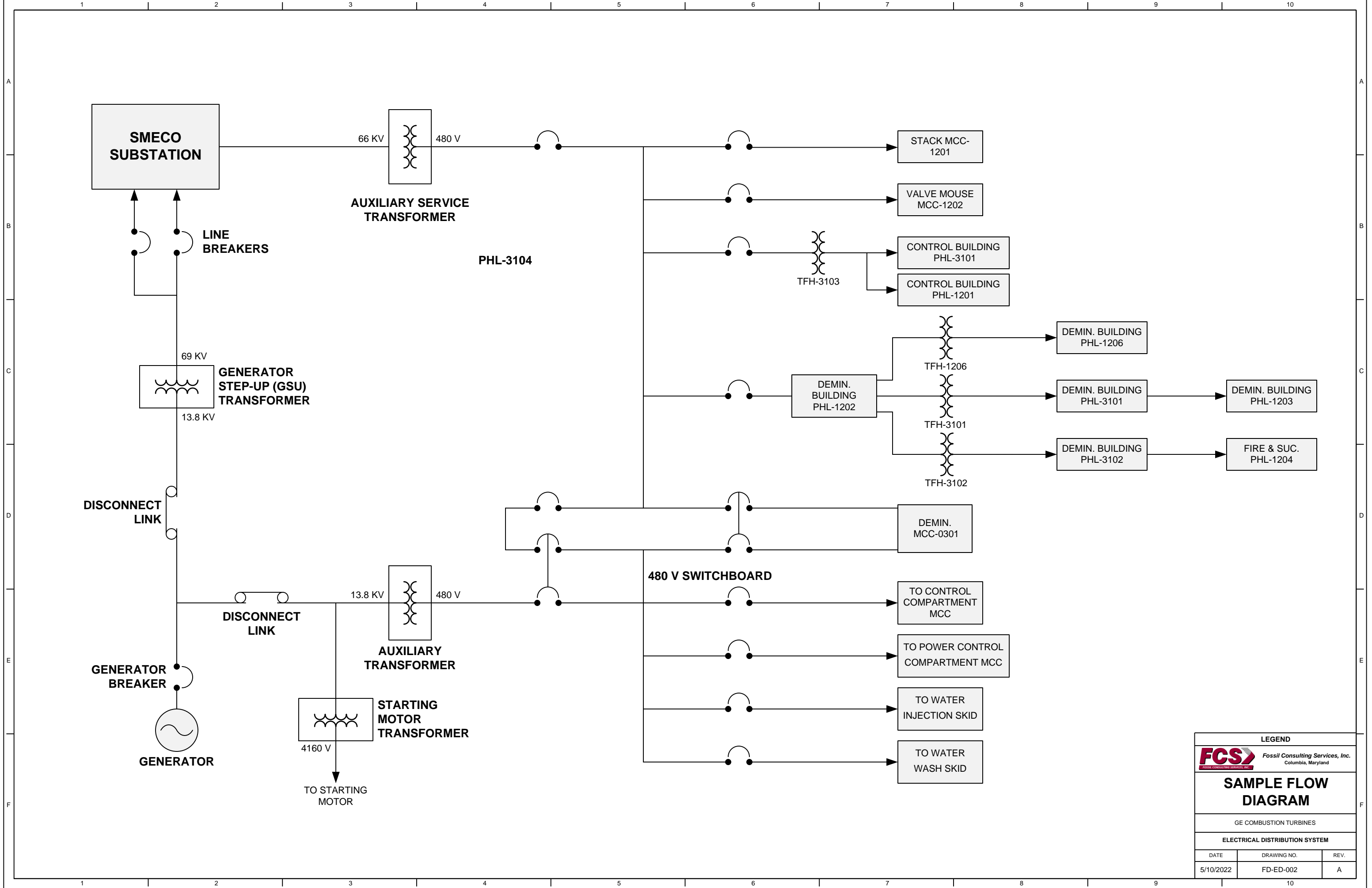

LEGEND		
 Fossil Consulting Services, Inc. Columbia, Maryland		
SAMPLE FLOW DIAGRAM		
GE COMBUSTION TURBINES		
ELECTRICAL DISTRIBUTION SYSTEM		
DATE	DRAWING NO.	REV.
5/10/2022	FD-ED-002	A

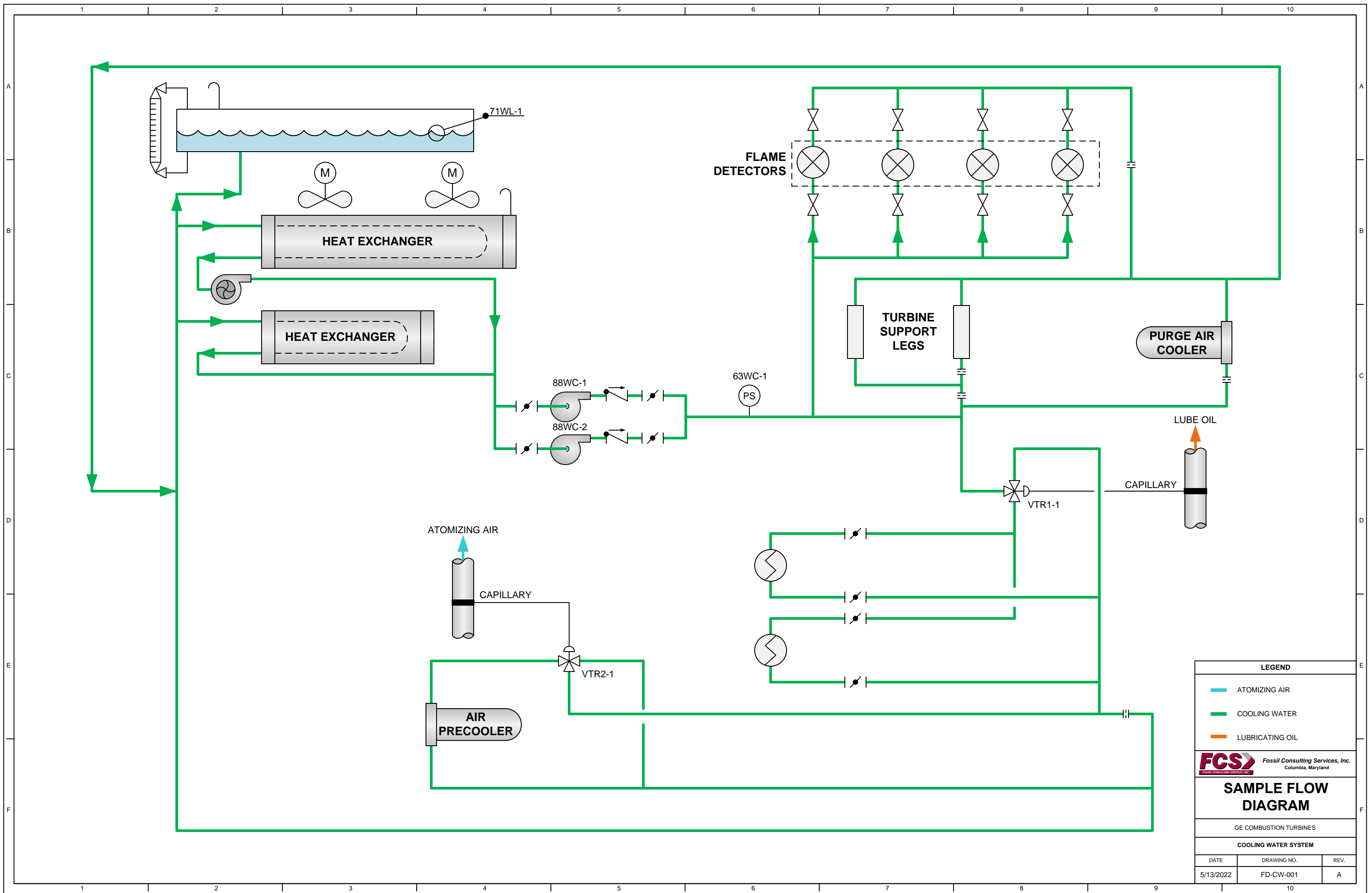

LEGEND		
—	ATOMIZING AIR	
—	COOLING WATER	
—	LUBRICATING OIL	
FCS Fossil Consulting Services, Inc. Columbia, Maryland		
SAMPLE FLOW DIAGRAM		
GE COMBUSTION TURBINES		
COOLING WATER SYSTEM		
DATE	DRAWING NO.	REV.
5/13/2022	FD-CW-001	A

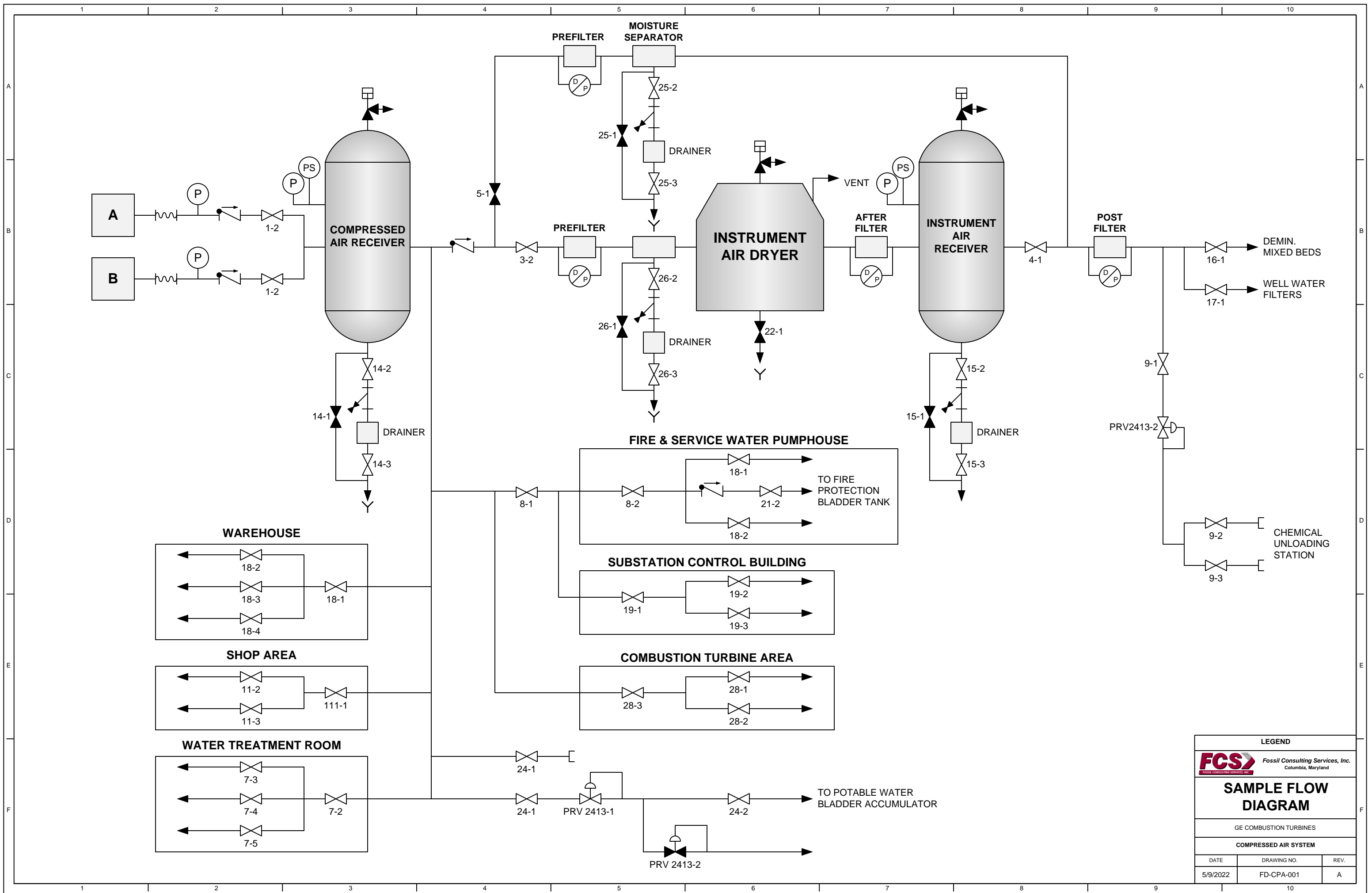

LEGEND		
 Fossil Consulting Services, Inc. Columbia, Maryland		
SAMPLE FLOW DIAGRAM		
GE COMBUSTION TURBINES		
COMPRESSED AIR SYSTEM		
DATE	DRAWING NO.	REV.
5/9/2022	FD-CPA-001	A

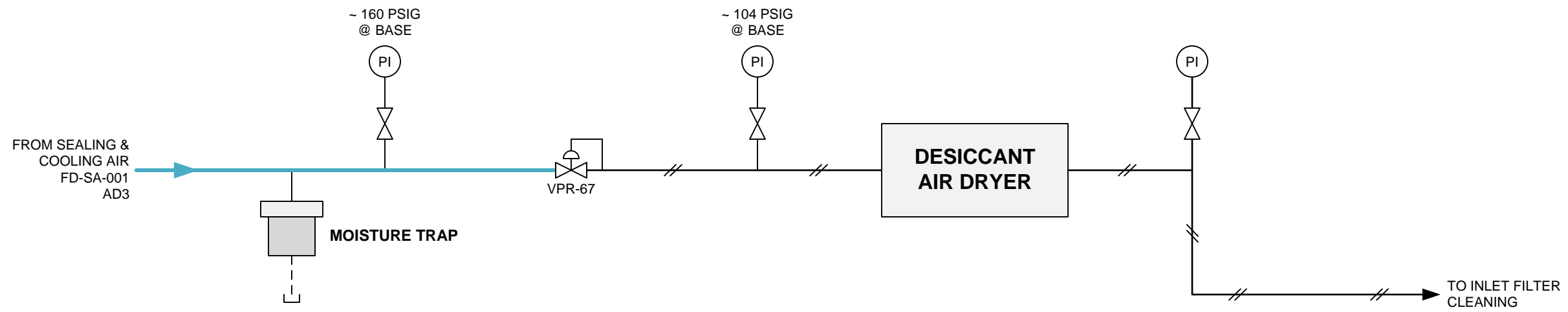

LEGEND		
	COOLING & SEALING AIR	
	CONTROL AIR	
Fossil Consulting Services, Inc. Columbia, Maryland		
SAMPLE FLOW DIAGRAM		
GE COMBUSTION TURBINES		
CONTROL AIR		
DATE	DRAWING NO.	REV.
5/9/2022	FD-CA-001	A